

AEG ID

Manual

ARE i2.0x HF



1.	Introduction	4
2.	ARE i2.0x HF	5
2.1	ARE i2.0x HF hardware	5
2.1.1	Dimensions ARE i2.0x HF	5
2.1.2	Protection Class.....	5
2.1.3	AAN Xi9F HF dimensions	5
2.1.4	Mounting and grounding.....	6
2.1.5	Connectivity:	6
2.1.6	Read Range for HF Applications using AAN Xi9F HF.....	7
2.2	Firmware ARE i2.0x HF	9
2.2.1	Instruction Set	9
2.2.2	General format of instruction set	9
2.2.3	BD	9
2.2.4	VER	10
2.2.5	TOR	10
2.2.6	GT	11
2.2.7	RD	11
2.2.8	WD	12
2.2.9	MD	12
2.2.10	CID	13
2.2.11	CN	13
2.2.12	VSAVE	13
2.2.13	INIT	14
2.2.14	Error messages.....	14
2.3	LED instruction set.....	15
2.3.1	LED Standby (LSTB).....	16
2.3.2	LED Reading (LGT).....	16
2.3.3	LED Transponder number successfully read (LRD)	17
2.3.4	LED No Read (LNRD)	17
2.3.5	LED Return to standby (LRT).....	18
2.3.6	LED Error (LERR).....	18

1. Introduction

ARE i2.0x HF is a compact industrial reader based on an RS-232 interface. This version is compatible with ISO 15693 applications. ARE i2.0x HF uses an external antenna for communication to the transponder. There are various antenna form factors available.

Typical system structure



2. ARE i2.0x HF

ARE i2.0x HF works with transponders that comply to HF standard ISO 15693.

2.1 ARE i2.0x HF hardware

2.1.1 Dimensions ARE i2.0x HF

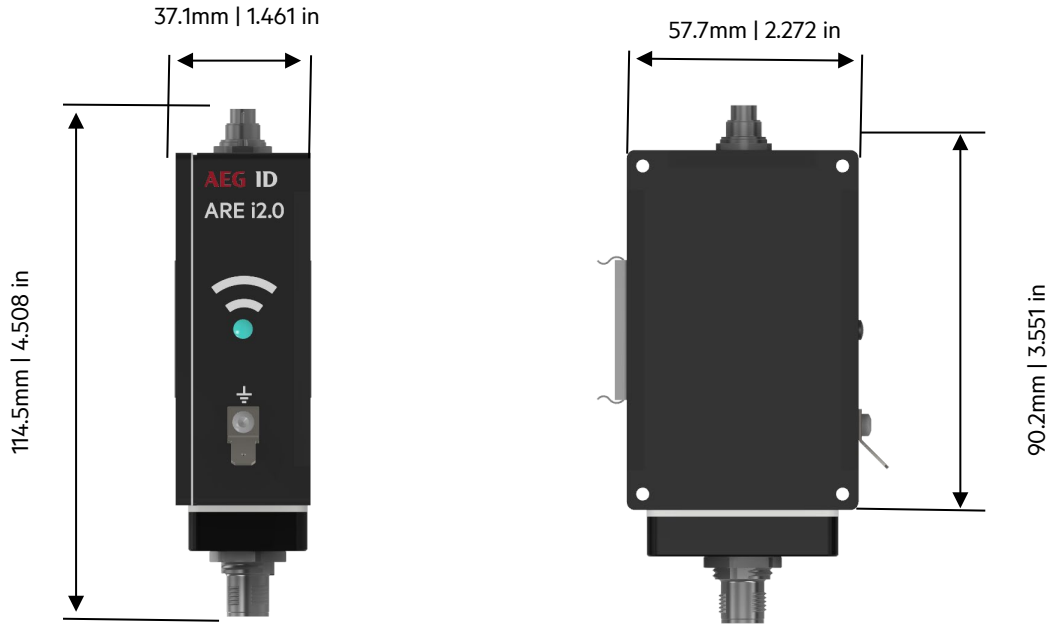

2.1.2 Protection Class

Protection Class is IP 67, assuming cable or dummy cap is mounted.

2.1.3 AAN Xi9F HF dimensions

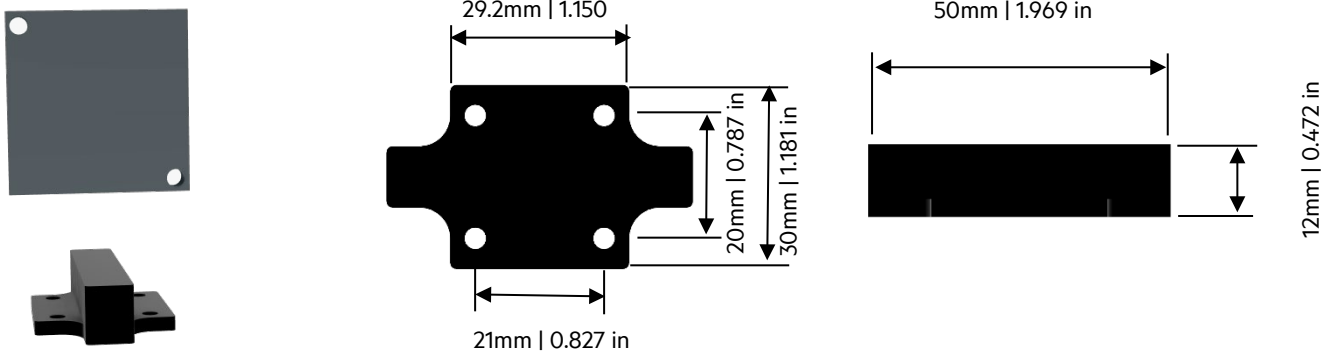

2.1.4 Mounting and grounding



Top hat rail connector
Connected to internal ground



Grounding pin can be used alternatively to ground ARE i2.0x HF



Mounting is recommended via the top hat rail connector on the back of the unit.

Note: Grounding of the unit can be achieved by grounding the top hat rail. The top hat rail connector is hooked up to internal system ground. Alternatively mounting straps are optionally available.

2.1.5 Connectivity:

ARE i2.0x HF is connected via its M12, 5-Pin male A-coded plug. Power supply as well as communication is provided by user. Do only use specified cables. ARE i2.0x HF uses a LED lit RFID symbol on its front side to visually communicate its various states (standby, reading, successful read, no read, error, and so on...). When ARE i2.0x HF is hooked up to power, the internal LED is switched to standby color. LED colors can be set by the user.

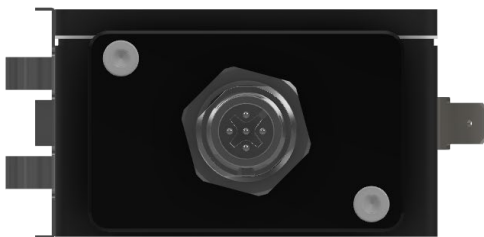

- PIN 1 – +12V...24V DC
- PIN 2 – GND
- PIN 3 – RX
- PIN 4 – TX
- PIN 5 – n/c



LED: Status indication

cable: M12, 5-Pin A-coded, (socket to power 2 cables) and serial interface 3 cables)

The antenna AAN Xi9F HF is connected via a 2-pin connector on top of ARE i2.0x HF.

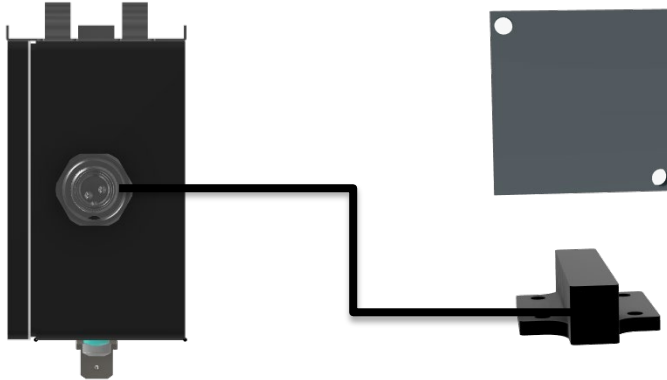

ARE i2.0x HF uses an external antenna AAN Xi9F HF. There are air core coil transponders like disks and ferrite core coil transponders like glass tube transponders. It is important to understand the impact of orientation of transponders relative to AAN Xi9F HF. Optimum orientation is perpendicular to the top side of the antenna for air core coil transponders. In this orientation, the highest read range can be achieved.

Reading distance depends a lot on the particular installation. Absolute values only make sense based on a particular transponder. Absolute values make no sense for transponder types, because the values will vary too much. Above are the guiding principles to achieve the best possible read range.

2.1.6 Read Range for HF Applications using AAN Xi9F HF

Transponder acc. to ISO 15693 (40mm x 40mm x 5mm)

transponder perpendicular (recommended)

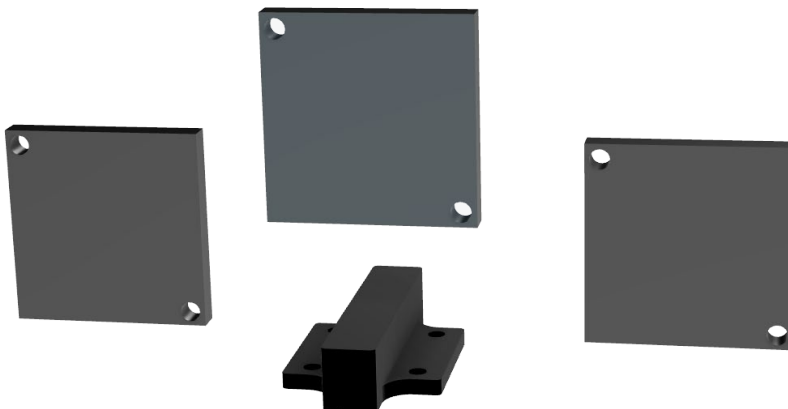

The highest read range is achieved right above the center of AAN Xi9F top side.

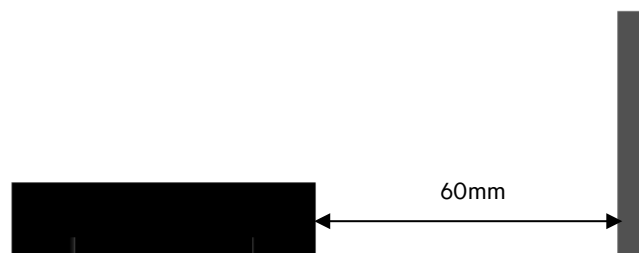
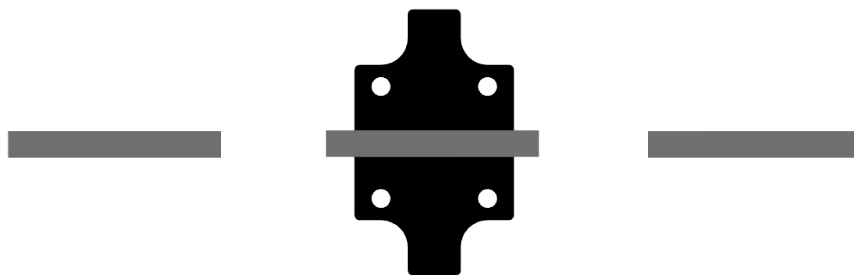
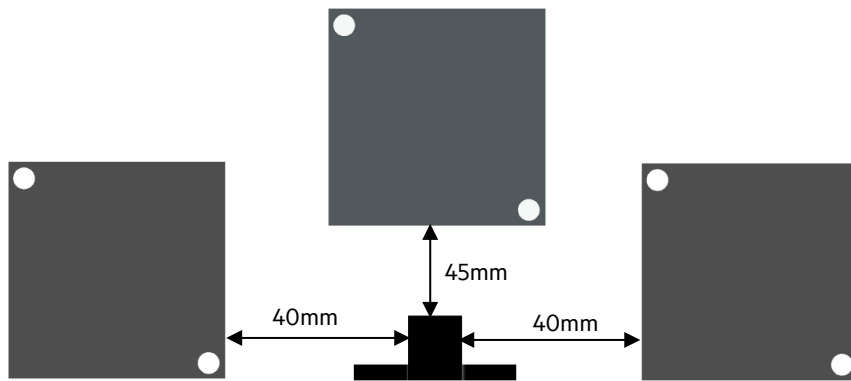

*note: only one transponder in the field at a time. Above illustration only shows possible read ranges.

2.2 Firmware ARE i2.0x HF

2.2.1 Instruction Set

Communication with ARE i2.0x HF is based on a simple ASCII text based protocol. The host sends text based telegrams to ARE i2.0x HF and receives text based telegrams back containing the answer to the query. Communication to ARE i2.0x HF is always triggered by the host.

2.2.2 General format of instruction set

The protocol format is as follows

Instruction <CR> for instructions without parameter

Instruction <SP> **parameter** <CR> for instructions with only 1 parameter

Instruction <SP> **parameter** <SP> **data** <CR> for instructions with parameter and data

The space character <SP> separates commands from parameters and data and the <CR> character acts as command line terminator.

instruction<CR> can be used to check the current parameter value for instructions that carry a parameter.

Input **Instruction** <CR> Answer: **Parameter**<CR>

2.2.3 BD

BD – Baudrate parameter sets the baudrate for ARE i2.0x. Please Note: Standard parameter is 19.200 baud.

Input format: BD<SP>Parameter<CR>
 e.g. BD<SP>2<CR>

Hex:	42	44	20	32	0D
ASCII:	'B'	'D'	<SP>	'2'	<CR>

Output (example): Baudrate 38.400 baud

Hex:	32	0D
ASCII:	'2'	<CR>

Parameter:

PARAMETER	BAUDRATE
0	4.800
1	9.600
2	19.200
3	38.400
4	57.600
5	115.200

2.2.4 VER

VER – Reader firmware version

VER is used to get the actual reader firmware version.

Input format: VER <CR>

Hex:	56	45	52	0D
ASCII:	'V'	'E'	'R'	<CR>

Output (example): ARE i2.0x HF V_1.065 <CR>

Hex:	21	00	15	...	36.	35	0D
ASCII:	'A'	'R'	'E'	...	'6'	'5'	<CR>

2.2.5 TOR

TOR – Timeout Reading

After a read is triggered by GT, TOR is a time during which ARE i2.0x HF continuously tries to read a transponder UID without the need to be triggered by the host again. This limits bus traffic considerably. Once a successful read is performed, continuous reading stops immediately regardless of time and the transponder UID is transmitted to the host. If reading is not successful, a no read (XXXXXXXX) is sent to the host after TOR time has expired. The chosen parameter for TOR is sent as acknowledgement.

Input format: TOR<SP>Time parameter<CR>
e.g. TOR<SP>50<CR>

Hex:	54	4F	52	20	35	30	0D
ASCII:	'T'	'O'	'R'	<SP>	'5'	'0'	<CR>

Output (example): 50 <CR>

Hex:	35	30	0D
ASCII:	'5'	'0'	<CR>

Parameter:

PARAMETER	FUNCTION
0	limits the reading process duration to exactly one reading cycle
1	limits the reading process duration to maximum 1 times 100ms
2	limits the reading process duration to maximum 2 times 100ms
...	
255	limits the reading process duration to maximum 255 times 100ms

A TOR value of 50 equals 50 x 100ms = 5000ms = 5 sec.

It is recommended to set TOR value to the amount of time it takes in a dynamic situation for the transponder to travel over ARE i2.0 HF. This maximizes the number of possible reads, in order to compensate for EMV noise in the vicinity.

2.2.6 GT

GT – Get Tag

GT is used to retrieve the transponder UID. GT uses TOR parameter to define the time during which the reader continuously looks for a transponder without the need for the host to get involved.

Input format: GT<CR>

Hex:	47	54	0D
ASCII:	'G'	'T'	<CR>

Output (example in case of a successful read): E0080100002B3706 <CR>

Hex:	45	30	30	...	30	36	0D
ASCII:	'E'	'0'	'0'	...	'0'	'6'	<CR>

Output (example in case of no transponder in the field): XXXXXXXX<CR>

Hex:	58	58	58	...	58	58	0D
ASCII:	'X'	'X'	'X'	...	'X'	'X'	<CR>

2.2.7 RD

RD – Read transponder memory page

RD is used to read an individual memory page from a transponder in the field. RD uses TOR parameter during which the reader continuously looks for a transponder without the need for the host to get involved.

Please see datasheet of transponder for specific memory map. Page is input as hex number.

Input format: RD<SP>page<CR>
RD<SP> 1<CR>

Hex:	52	44	20	31	0D
ASCII:	'R'	'D'	<SP>	'1'	<CR>

Output (example in case of a successful read): 1234567812345678<CR>

Hex:	31	32	33	38	0D
ASCII:	'1'	'2'	'3'	'8'	<CR>

Output (example in case of no transponder in the field): XXXXXXXX<CR>

Hex:	58	58	58	...	58	58	0D
ASCII:	'X'	'X'	'X'	...	'X'	'X'	<CR>

Manual ARE i2.0x HF release V5	Version:	13
	Page:	12 / 25

2.2.8 WD

WD – Write transponder memory page

WD is used to write to individual memory page of a transponder in the field. WD uses TOR parameter during which the reader continuously looks for a transponder without the need for the host to get involved.

Please see datasheet of transponder for specific memory map. Page is input as hex number.

Input format: WD<SP>page<SP>data<CR>
 WD<SP> 5<SP> 12345678ABCDEF78<CR>

Hex:	57	44	20	35	20	31	...	38	0D
ASCII:	'W'	'D'	<SP>	'5'	<SP>	'1'	...	'8'	<CR>

Output (example in case of a successful write): ACK<CR>

Hex:	41	43	4B	0D
ASCII:	'A'	'C'	'K'	<CR>

Output (example in case of no transponder in the field): XXXXXXXX<CR>

Hex:	58	58	58	...	58	58	0D
ASCII:	'X'	'X'	'X'	...	'X'	'X'	<CR>

2.2.9 MD

MD – Read mode

MD is used to either read the chip UID once per trigger by the host (e.g GT command) or read the chip UID continuously after a trigger by the host until mode is switched back to single read

Parameters: 2 – single read (default) | 0 – continuous read mode

Input format: MD<SP>parameter<CR>
 MD<SP> 0<CR>

Hex:	4D	44	20	30	0D
ASCII:	'M'	'D'	<SP>	'0'	<CR>

Output (example): 0x1<CR>

Hex:	30	0D
ASCII:	'0'	<CR>

2.2.10 CID

CID – Filter same UID numbers to transmit only once via interface

CID is used to filter multiple read transponder UID to transmit only once via interface. There needs to be one different Transponder UID read before the same number will be transmitted again.

Parameters: 0 – no filter function | 1 – filter same chip UID as previously read

Input format: CID<SP>1<CR>

Hex:	43	49	44	20	31
ASCII:	'C'	'I'	'D'	<SP>	'1'

Output (example): 0x1<CR>

Hex:	31	0D
ASCII:	'1'	<CR>

2.2.11 CN

CN – Filter no read from being transmitted via interface.

CN is used in those cases, where no read information 'xxxxxxx' should not appear on the interface. Only valid transponder UID will be transmitted.

Parameters: 0 – no filter function | 1 – filter no read information from being transmitted

Input format: CN<SP>1<CR>

Hex:	43	4E	20	31
ASCII:	'C'	'N'	<SP>	'1'

Output (example): 0x1<CR>

Hex:	31	0D
ASCII:	'1'	<CR>

2.2.12 VSAVE

VSAVE – Save parameter permanently in ARE i2.0x HF flash memory

VSAVE is used to save parameters permanently in flash memory of ARE i2.0x HF to be available after power on.

Input format: VSAVE <CR>

Hex:	56	53	41	56	45	0D
ASCII:	'V'	'S'	'A'	'V'	'E'	<CR>

Output (example): ACK<CR>

Hex:	41	43	4B	0D
ASCII:	'A'	'C'	'K'	<CR>

2.2.13 INIT

INIT – Restore standard parameters. Command needs to be followed up by VSAVE in order to permanently store the parameters.

Input format: INIT<CR>

Hex:	49	4E	49	54	0D
ASCII:	'I'	'N'	'I'	'T'	<CR>

Output (example):ACK<CR>

Hex:	41	43	4B	0D
ASCII:	'A'	'C'	'K'	<CR>

The following parameters are set:

BD 3	LRD 01001
TOR 50	LNRD 10001
CID 0	LERR 10011
CN 0	LRT 30
MD 2	LPA 00000
LSTB 01101	LED 1
LGT 01111	

2.2.14 Error messages

Error messages and protocol errors are acknowledged by ARE i2.0 HF using an error code. The format is described below:

<NAK> '#' <error code> <CR>

Example error #02 (wrong parameter)

Hex:	15	23	30	32	0D
ASCII:	<NAK>	'#'	'0'	'2'	<CR>

The error code is comprised of a two digit ASCII coded number.

The following table displays possible error messages:

Error code	Meaning
"00"	Unknown instruction
"02"	Wrong parameter

2.3 LED instruction set

ARE i2.0 HF employs a multi-color LED to signal different modes.

Basically below colors can be created:

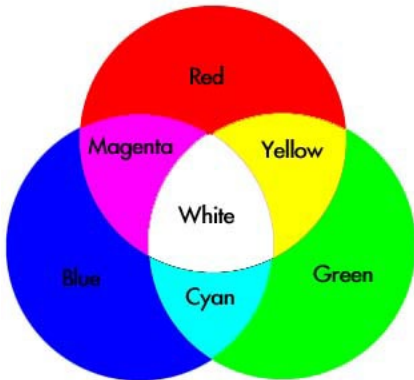

The user can choose any color apart from white. This color is reserved for setup help functionality as described below.

The following modes use a distinct color each.

- Standby (LSTB)
- Reading (LGT)
- Transponder number successfully read (LRD)
- No Read (LNRD)
- Error (LERR)
- Process active (LPA)
- Process status (LPS)

In addition, the user can choose to switch on the LED permanently or flashing.

The following instruction set is used:

Mode<SPACE>RGBFX<CR>

R – Red

G – Green

B – Blue

F - Flash

X – LED functionality ON or OFF for this mode

Allowed parameters are 1 (on) or 0 (off)

Default colors are shown with the instructions.

2.3.1 LED Standby (LSTB)

Standby color is **Cyan**, no flash.

Input format: LSTB<SP> 01101<CR>

Hex:	4C	53	54	42	20	30	...	31	0D
ASCII:	'L'	'S'	'T'	'B'	<SP>	'O'	...	'I'	<CR>

Output: 01101<CR>

Hex:	30	31	31	30	31	0D
ASCII:	'O'	'I'	'I'	'O'	'I'	<CR>

Standby mode is active if no other instructions are carried out.

If Standby LED is switched off, the LED will be active for 10 seconds after reboot in its last color scheme and then it will be switched off.

2.3.2 LED Reading (LGT)

Reading color is **Cyan**, flashing

Input format: LGT<SP> 01111<CR>

Hex:	4C	47	54	20	30	31	...	31	0D
ASCII:	'L'	'G'	'T'	<SP>	'O'	'I'	...	'I'	<CR>

Output: 01111<CR>

Hex:	30	31	31	31	31	0D
ASCII:	'O'	'I'	'I'	'I'	'I'	<CR>

Reading mode is active for the duration of the TOR parameter. It will stop prematurely only to show a successful read using the respective color. At the end of the TOR parameter it will show the no read mode LED color.

2.3.3 LED Transponder number successfully read (LRD)

Successful read color is **green**, no flash

Input format: LRD<SP> 01001<CR>

Hex:	4C	52	44	20	30	31	...	31	0D
ASCII:	'L'	'R'	'D'	<SP>	'0'	'1'	...	'1'	<CR>

Output: 01001<CR>

Hex:	30	31	30	30	31	0D
ASCII:	'0'	'1'	'0'	'0'	'1'	<CR>

Successful read mode is active for LRT seconds, after which the standby mode will be active again.

2.3.4 LED No Read (LNRD)

No Read color is **red**, no flash

Input format: LNRD<SP> 10001<CR>

Hex:	4C	4E	52	44	20	31	...	31	0D
ASCII:	'L'	'N'	'R'	'D'	<SP>	'1'	...	'1'	<CR>

Output: 10001<CR>

Hex:	31	30	30	30	31	0D
ASCII:	'1'	'0'	'0'	'0'	'1'	<CR>

No Read mode is active after TOR seconds for LRT seconds, after which the standby mode will be active again.

2.3.5 LED Return to standby (LRT)

Some modes require ARE i9 to go back to standby. The time until this happens is set by using the LRT command.

Input format: LRT<SP>time<CR>

Hex:	4C	52	54	20	33	30	0D		
ASCII:	'L'	'R'	'T'	<SP>	'3'	'0'	<CR>		

Output: 30<CR>

Hex:	33	30	0D
ASCII:	'3'	'0'	<CR>

LRT<SP>30<CR> sets approx. 3 seconds as time for return to standby (30x100ms)

2.3.6 LED Error (LERR)

Error color is **red**, flashing

Input format: LERR<SP> 10011<CR>

Hex:	4C	45	52	52	20	31	...	31	0D
ASCII:	'L'	'E'	'R'	'R'	<SP>	'1'	...	'1'	<CR>

Output: 10011<CR>

Hex:	31	30	30	31	31	0D
ASCII:	'1'	'0'	'0'	'1'	'1'	<CR>

Error mode is triggered by an error of ARE i9 and is active until a correct instruction is received.

2.3.7 LED Process active

In case of multiple commands being sent to the chip (e.g. rd and wd instructions), it may be necessary to control LED functionality manually. The LED Process active instruction sets the LED to a defined color and mode. This color and mode stays on as long as the LED Process active parameter is switched on. Normal LED functionality is discontinued during the activity of this parameter. LED functionality returns to normal only when LED Process active is switched off via its X parameter.

Activating Process active

LED color is **yellow**, flashing

Input format: LPA<SP> 11011<CR>

Hex:	4C	50	41	20	31	31	0D
ASCII:	'L'	'P'	'A'	<SP>	'1'	'1'	<CR>

Output: 11011<CR>

Hex:	31	31	30	31	31	0D
ASCII:	'1'	'1'	'0'	'1'	'1'	<CR>

Deactivating Process active

LED color doesn't care, because parameter is switched off using X parameter

Input format: LPA<SP> 11010<CR>

Hex:	4C	50	41	20	31	30	0D
ASCII:	'L'	'P'	'A'	<SP>	'1'	'0'	<CR>

Output: 11010<CR>

Hex:	31	31	30	31	30	0D
ASCII:	'1'	'1'	'0'	'1'	'0'	<CR>

2.3.8 LED Process status

LED Process status is used to indicate the status of a process, after it is performed.

Successful Process

LED color is **green** not flashing

Input format: LPS<SP> 01001<CR>

Hex:	4C	53	54	20	30	31	...	31	0D
ASCII:	'L'	'P'	'S'	<SP>	'0'	'1'	...	'1'	<CR>

Output: 01001<CR>

Hex:	30	31	30	30	31	0D
ASCII:	'0'	'1'	'0'	'0'	'1'	<CR>

Not Successful Process

LED color is **red**, not flashing

Input format: LPS<SP> 10001<CR>

Hex:	4C	53	54	20	31	30	...	31	0D
ASCII:	'L'	'P'	'S'	<SP>	'1'	'0'	...	'1'	<CR>

Output: 10001<CR>

Hex:	31	30	30	30	31	0D
ASCII:	'1'	'0'	'0'	'0'	'1'	<CR>

LPS stays on for LRT seconds and then returns to standby.

2.3.9 LED Setup help (FLED)

In order to locate the respective ARE i2.0 HF hooked up to a particular RS 232 port, the instruction FLED is used.

This instruction flashes the LED in white for 10 seconds. The color can not be changed.

Input format: FLED<CR>

Hex:	4C	53	54	42	0D
ASCII:	'F'	'L'	'E'	'D'	<CR>

Output: FLED<CR>

Hex:	4C	53	54	42	0D
ASCII:	'F'	'L'	'E'	'D'	<CR>

After flashing for 10 seconds ARE i9 returns to standby mode.

2.3.10 LED (De)activate LED functionality (LED)

In order to deactivate (or activate) the LED functionality, LED instruction is used.

Input format: LED<SP>Parameter<CR>

Hex:	53	54	42	20	30	0D			
ASCII:	'L'	'E'	'D'	<SP>	'0'	<CR>			

Output: 0<CR>

Hex:	30	0D
ASCII:	'0'	<CR>

LED<SP> 0<CR> deactivates LED functionality.

LED<SP> 1<CR> activates LED functionality (default).

Above examples represent ARE i2.0 HF default values.

3. System implementation

3.1 Power supply

HF industry uses hdx LF RFID technology. This particular method relies on field gaps, where the RFID field is switched off. In this gap the transponder answers with its code. This method has the advantage of high read range in laboratory conditions. However, in a EMV polluted environment, read range of hdx transponders is significantly reduced as even low noise signals have a direct impact on read range.

Therefore it is absolutely mandatory for system integration to make sure that power supply for ARE i2.0x HF is absolutely stable and clean with no noise. It is recommended to use linear power supplies rather than switching power supplies. All other applications benefit from this as well.

3.2 Grounding

Please make absolutely sure that ARE i2.0x HF is properly grounded. This ensures proper functionality of the entire system comprising of ARE i2.0x HF and AAN Xi9F. Please see chapter 2.1.4 for details on grounding.

Grounding can be achieved by grounding DIN hat rail, as clamp on backside of ARE i2.0x HF is connected to ground. Alternatively, the grounding pin on the frontside of ARE i2.0x HF can be used to achieve this.

3.3 Mounting on metal

ARE i2.0x HF is typically mounted on a metal DIN hat rail in a metal electrical cabinet. There is no influence of metal on performance of ARE i2.0x HF and therefore nothing to watch out for.

It is recommended to mount AAN Xi9F HF onto a non-conductive surface. However, AAAN Xi9F HF is designed to work when mounted on metal as well. There is a slight decrease in read/write range when compared to mounting on non-conductive surfaces, but in most cases the read/write range will still be plenty for the application.

3.4 Frequency converters

Frequency converters used in electronic motors are a source of significant EMV noise. Make sure to stay away as far as possible from those frequency converters when designing spots where ARE i2.0x HF to be used. Noise from frequency converters significantly reduce read range of ARE i2.0x HF.

4. FCC Statement

4.1 ARE i2.0x HF

Valid for ARE i2.0x HF

Federal Communications Commissions (FCC) Statement

§15.21

You are cautioned that changes or modifications not expressly approved by the part responsible for compliance could void the user's authority to operate the equipment.

§15.105 Information to the user.

Note: This equipment has been tested and found to comply with the limits for a Class B digital device, pursuant to part 15 of the FCC Rules. These limits are designed to provide reasonable protection against harmful interference in a residential installation. This equipment generates, uses and can radiate radio frequency energy and, if not installed and used in accordance with the instructions, may cause harmful interference to radio communications. However, there is no guarantee that interference will not occur in a particular installation. If this equipment does cause harmful interference to radio or television reception, which can be determined by turning the equipment off and on, the user is encouraged to try to correct the interference by one or more of the following measures:

- Reorient or relocate the receiving antenna.
- Increase the separation between the equipment and receiver.
- Connect the equipment into an outlet on a circuit different from that to which the receiver is connected.
- Consult the dealer or an experienced radio/TV technician for help.

5. Release, Change Protocol

Revision:	Date:	Changes:	Author:
01	28.05.2023	Release first edition	NK
02	08.06.2023	Antenna connector change for ARE i2.0x HF	NK
03	23.08.2023	No read message correction	NK
04	11.11.2023	Details added	NK
05	08.05.2024	Details added	NK

AEG ID

AEG Identifikationssysteme GmbH

Hörvelsinger Weg 47

89081 Ulm

Tel.: +49 731 14 00 88 – 0

Email: sales@aegid.de

Web: www.aegid.de

AEG is a registered trademark used under license from AB Electrolux (publ)